



# ALPHAONE™

MACHINE FILM

## Multipurpose Stretch Machine Film

AlphaOne provides moderate to high pre-stretch levels and quality pallet integrity.

### Features & Benefits

- Cast machine film
- Performance film
- Two-sided cling
- High clarity
- Dependable load containment

### Ideal for

- Most applications
- Loads: A, B, and C

JDE #	PRODUCT CODE	GAUGE	MICRONS	WIDTH (IN)	LENGTH (FT)	POUNDS PER ROLL	ROLLS PER PALLET
1504700	A120115	115	29.2	20	3750	34.5	40
A12050	A12050SNS	50	12.7	20	9000	36.0	40
1504789	A12060	60	15.2	20	7500	36.0	40
A12063	A12063SNS	63	16.0	20	6000	30.24	40
1504779	A12070	70	17.8	20	6500	36.4	40
1504727	A12075	75	19.0	20	5000	30.0	40
1504751	A12080	80	20.3	20	6000	38.4	40
1504729	A12080L5	80	20.3	20	5000	32.0	40
1504737	A12090	90	22.9	20	5000	36.0	40
1504838	A13060	60	15.2	30	7500	54.0	20
1504835	A13070	70	17.8	30	6500	54.6	20
1504824	A13080	80	20.3	30	6000	57.6	20

Contact us at [stretchfilms@berryglobal.com](mailto:stretchfilms@berryglobal.com) or 1.877.662.3779 to place an order

AlphaOne™ is a trademark of Berry Global, Inc. or one of its affiliates



Two-sided cling

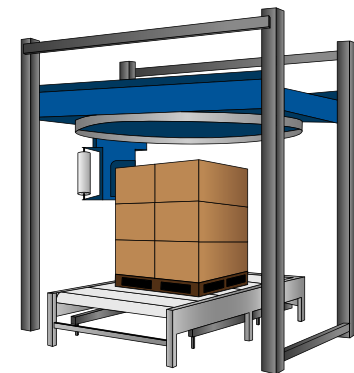

INNOVATION FOR THE WORLD  
SOLUTIONS FOR YOU



**Berry Global leverages our sustainability leadership, unmatched global capabilities, and deep innovation expertise to serve customers of all sizes around the world.**

 **Sustainability Leadership**

Collaborating Across the Value Chain to Achieve More Together for a Circular Economy

 **Global Capabilities**

Serving Customers of All Sizes Around the World with our Unmatched Global Capabilities

 **Innovation Expertise**

Creating Innovative Packaging and Engineered Products that Make Life Better for People and the Planet

1.877.662.3779 | [berryglobal.com](http://berryglobal.com)

# Our Customer Promise

We partner with customers to develop, design, and manufacture innovative products with an eye toward the circular economy. The challenges we solve and the innovations we pioneer benefit our customers at every stage of their journey.

